

	1			CPCD40
	2			
	3		kg	4000
	4		mm	500
	5		kg	5480
	6	, /	kg	8335/1145
	7	, /	kg	2225/3255
	8			
	9	/		2/2
	10		mm	1880
	11			250-15-18PR
	12			7.00-12-12PR
	13	/	mm	1180/1112
	14		mm	3000
	15		mm	130
	16	,	mm	2175
	17	,	mm	4180
	18	, /	deg	6°/12°
	19		mm	1380
	20	/	mm	330/1380
	21	x x	mm	122x50x1070
	22		mm	2950
	23		mm	1420
	24		mm	2175
	25		mm	2680
	26		mm	510
	27		mm	4460
	28		mm	145
	29		mm	175
	30	/	km/h	18.5/19
	31	/	mm/s	390/410
	32	/	mm/s	400/410
	33		N	19613
	34	/	%	20/18
	35			/ -
	36			/
	37			Isuzu
	38			4JG2-B-A-05-C2
	39	.		EU Stage II
	40			4
	41		L	3.059
	42		kw/rpm	44.9/2450
	43	.	N.m/rpm	184.7/1700

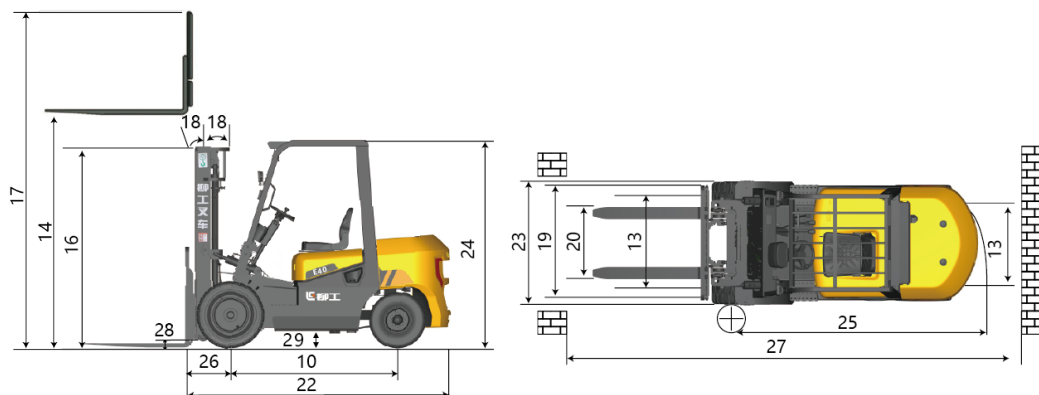

LIUGONG

E



Isuzu

4000 kg
44.9 kW

CPCD40

E